

Hand crafted spinning wheels and a wide range of woolworking tools for beginners and experts

**Majacraft Ltd**  
586 Oropi Road  
RD.3  
Tauranga 3173  
ph: +64 (7) 543-3618  
fax: +64 (7) 543-3718  
email: support@majacraft.co.nz

## **SUZIE, SUZIE PROFESSIONAL AND SUZIE ALPACA DOUBLE TREADLE SPINNING WHEEL**

### INSTRUCTIONS FOR ASSEMBLY AND USE

PLEASE READ THESE NOTES BEFORE YOU UNPACK THIS BOX

**1** Your wheel has been assembled at our workshop; it has been tested; it has been spun on; all screws have been pre-fitted and some have been removed for partial disassembly.

Please unpack with care and retain the packaging. In the box will be:

- a base
- a handle column/drive wheel assembly
- 3 bobbins
- an inner box

The inner box will contain

- the spinning head
- flyer
- bobbin
- pedals
- crank set
- hardware (screws, etc) spare screws are included.

You will require for assembly a ½"(13mm) wrench or adjustable spanner, a No. 2 Phillips or pozi drive screw driver.

*This can usually be found in the tool kit of most cars.*

**2** Place the base upon the floor or table, with the twelve pedal hinge holes in the front of the foot and the Majacraft badge towards you.

**3** Insert the handle/drive wheel assembly into the base, with the bobbin bar facing the same way as the gold Majacraft badge on the base, and line up the screw holes in the sides with the holes in the handle/drive wheel assembly.

**4** Insert and partially tighten the eight 1 ½" gold screws, checking that they are in the original holes before finally tightening all eight screws. Now stand the base up.

**5** Loosen the wooden handle nut slightly and rotate the carrying grip end of the handle upward to move the head end to the top. Re-tighten the wooden handle nut.

- 6** Take the silver bolt, silver dome nut and wooden spacer from the top of the handle assembly. Place the spinning head between the uprights. It is possible to have a left or right handed option simply by installing the head so that the flyer spindle/whorl is either on the right or left of the handle column. Choose the side which will best suit you and your method of spinning. This may be changed quickly and easily at any time, but most spinners have the flyer and bobbin to their left.

With the spacer between the uprights, push the bolt away from you into the squarish hole toward the drive wheel side of the spinning wheel turning the bolt to fit its head into the recess. Place the washer at the rear of the handle and then tighten the nut at the rear using the 1/2" wrench or adjustable spanner to secure the head in place.

*Your wheel should now look like this.....*

- 7** The gap between the spinning head and the wooden spacer should be about 1/2" to give correct belt tension. Fit the drive belt and check that the belt will be tight enough on the smallest whorl/groove/largest wheel groove combination tipping the head to tighten the belt if necessary, then tighten the silver dome nut firmly.

- 8** Fit the pedals using the twelve gold 5x<sup>3</sup>/<sub>4</sub>" screws provided, matching the holes at the front of the base. The long side of the pedal goes nearest to the central base.

- 9** Fit the crank set to the drive wheel using the 1" silver screws provided. There are three holes arranged so that you can only fit the crank the correct way.

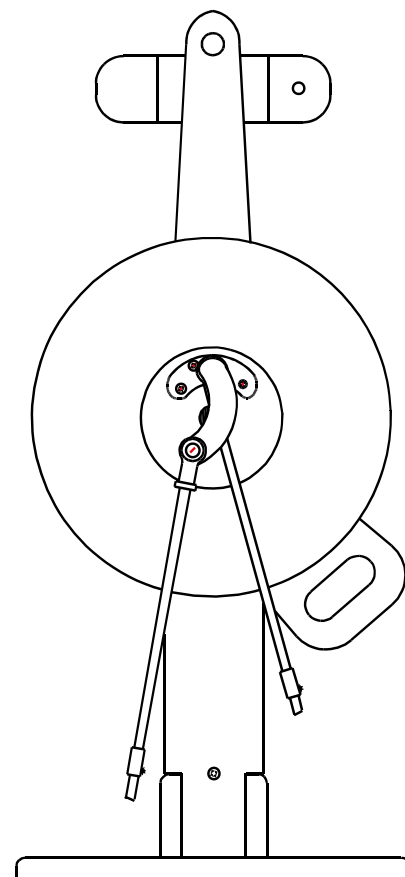

- 10** Fit the green joiners in the aluminium footmen to the pedals. *We leave one green flexible joint in one rod and one green joiner in a pedal to ensure that you can only attach each rod to it's correct pedal*

*With your Alpaca wheel, look for matching marks on the side of the wooden footman and the side of the pedal, this indicates which pedal to connect to which footman.*

Tighten the gold 1" screw in the pedals onto the green joiners which should be approximately flush with the underside of the pedal. Tighten the small silver screw on the footman to secure the green joiner.

Ensure that the centre bearing is substantially parallel to the crank and drive wheel, and that the outer bearing is also straight and parallel. You may need to turn the green joiner in the pedal to achieve this. This is most important.

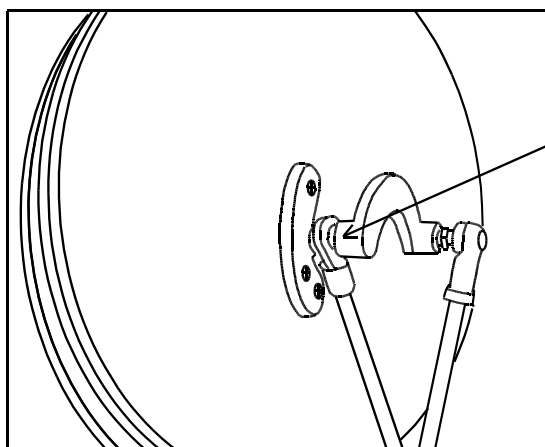

CORRECT

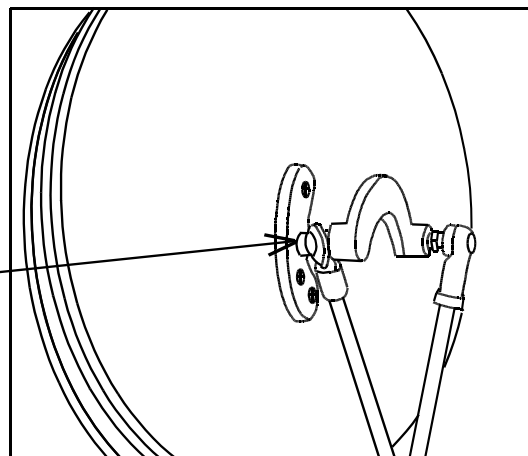

INCORRECT  
BEARING IS  
TWISTED

**11** Fit the drive band into the grooves nearest to you, forget about fibre for the moment, get yourself a chair and....

*place your heels as shown in the sketch - both feet on the pedals with the heels close to the end of the pedals and learn to treadle*

*The pedals are angled to ease foot strain, sit down firmly, sit back, please do not sit too close to the wheel and now treadle with your ankles and relax your body.*

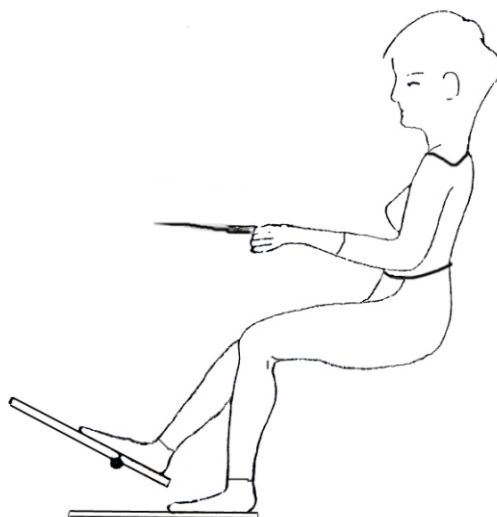

**12** When you are comfortable about treadling, tie on a leader and lead the fibre from the bobbin, around the inside hook of the stainless steel sliding yarn guide, around the flyer hook and down through the orifice. New bobbins may appear tight on the shaft - just push them on and off the shaft a couple of times from either end to free any slivers of plastic that remain inside the bobbin.

The sliding yarn guide on the flyer works best with the tips pointing away.

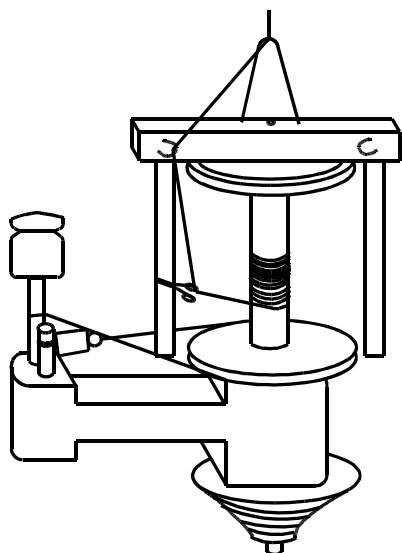

*Tie your leader around the core and not through the holes A piece of scotch tape will secure it firmly.*

The brake band (tension cord) is crossed for clockwise spinning.

It can be reversed if you are plying anticlockwise but its important that the tension is always against the knob, not against the spring.

To thread the wheel, pass the yarn only through one eye of the sliding hook, then round the fixed hook on the flyer and out through the orifice

- when changing the bobbin, hold the whorl to stop it turning, slacken the flyer with the other hand then treadle backwards and the flyer will unwind. If it doesn't you are treading the wrong way. Now you can change the bobbin. Rewind the flyer by treading clockwise.
- the bobbin is thin walled, lightweight and very responsive to tension adjustments.
- it has an increased yarn capacity.
- it has super smooth cord grooves
- it is functional and very strong
- it may be immersed in boiling water and other substances to set twist and dyes

**13** To move the flyer hook just squeeze the wings gently and slide it, bobbin filling can now be even, no more hills and valleys, it will be easier for unwinding. To spin wool fibres use the drive wheel/whorl grooves nearest to you. As you change to Merino, silk, cotton, etc, you will be using the grooves further away from you.

**14** It is correct practice with a band brake to spin with the pull of the cord on the tension knob and not on the spring. The spring is there to provide constant tension and not to flutter under the influence of bobbin rotation. Spin clockwise with the brake band crossed, with the cord going from the knob, down under and around the bobbin and back down to the spring. Uncross the cord to ply or spin anticlockwise.... see the previous sketches showing the yarn path, they also show the brake band crossed for clockwise rotation. Always use the minimum tension for satisfactory draw in and no more, There is sufficient spare cord supplied for you to remove a worn piece, and please, if you have to replace it, use a braided material and NOT mono filament fishing line which will cut a groove in any bobbin.

**15** Keep bobbin grooves clean. Cotton and silk must be spun with virtually no tension, no friction drag of any dirt in the groove and the flyer shaft must be clean too. Give the shaft a wipe with very light oil and wipe it off again. A little light oil on the pedal hinges occasionally, and on the centre crank bearing, say once a year, may help.

**16** The bobbin bar at the front of your wheel is used to store bobbins.

**17** The woodwork of your wheel has been varnished with a pre-catalysed lacquer, a wipe with a damp cloth is usually all that is needed, a drop of detergent on the damp cloth for a really dirty wheel may help. A mark made by a hard knock can be masked by putting a drop of furniture or linseed oil on the spot and allowing it to soak in. Please note that like all natural timber products your wheel needs to be kept away from direct sunlight, hot fires and if possible, extremely dry or humid environments. Majacraft has a polish made from organic lavender oil and manuka beeswax which is very effective in keeping your wheel attractive.

**18** Use the small grooves in the whorl for fine spinning. The large whorl grooves can be used for thicker yarns. The ratios for the Suzie and Suzie Professional are approximately.....

<b>largest whorl groove</b>	4:1
	6.3:1
	9.2:1
	11.5:1
<b>smallest whorl groove</b>	15:1

The ratios for the Suzie Alpaca are approximately.....

<b>largest whorl groove</b>	3.2:1
	4.6:1
	6.2:1
	8.7:1
<b>smallest whorl groove</b>	12:1

There are also intermediate ratios available by moving the belt on the drive wheel. When positioning the whorl on the flyer shaft, check that it is lined up with the wheel and also that the screw is tightened onto the flat area on the shaft.

**19** To fold the wheel for easy transportation, loosen the wooden handle nut slightly and rotate the head end of the handle downward to move the carrying grip to the top. Re-tighten the wooden handle nut. When folding the wheel leave the bobbin in place to protect the large whorl - a piece of cloth between the pedal and the spinning head will help protect the pedals. Reverse these instructions to return the handle to the spinning position

---

Majacraft manufactures a wide range of accessories for your spinning wheel.

Visit our web site at [www.majacraft.co.nz](http://www.majacraft.co.nz) to learn more or contact your dealer for a full colour brochure.

**Majacraft guarantees to replace or repair all faulty parts free of charge for two years from original purchase. Fair wear and tear resulting from usage excluded. In the unlikely event of a failure please contact your dealer.**

## WARNING

There are many moving parts on spinning wheels when in use. It is possible that moving parts could cause injury.

We urge you to take care and be aware of others, especially small children, so that your spinning brings a lifetime of pleasure.

